



Fountain With Back Panel

MODEL: OVL-II™ SBP



This fountain is **Classified by Underwriters Laboratories, Inc. in accordance with ANSI/NSF 61, Section 9 - 1997b.**

GENERAL

Oval shape face-mounted fountain, one-piece, non-corrosive stainless steel with brushed satin finish. Contour-formed basin with rounded corners and edges reduces splatter, insures proper drainage and prevents standing waste water. Oval fountain shape requires less neck extension and bending.

BUBBLER

Exclusive one-piece, chrome-plated two-stream mound-building bubbler with non-removable anti-squirt feature and integral hood insures a satisfying drink of water.

PUSH BAR ACTUATION MECHANISM

Self closing, semi-circular push bar can be actuated at any point of it 180° radius.

PANEL

Constructed of stainless steel, number 300 series with satin finish.

AUTOMATIC STREAM HEIGHT REGULATOR

Self-closing assembly is located inside unit to prevent tampering. Unit resists corrosion and liming. A constant stream height is automatically maintained under line pressures that vary from 20 to 105 psi.

INLET STRAINER

Easily cleaned in-line strainer screen traps particles of 140 microns or larger before they enter the waterway.

WATER INLET

3/8" O.D. Tubing

DRAIN OUTLET

1-1/4" tube outlet for 1-1/4" slip joint connection.

SUGGESTED SPECIFICATIONS

Fountain shall include pushbar on the front. Shall include contour-formed basin to eliminate splashing and standing water, and shall have rounded corners and edges. Projector shall be two-stream, mound-building type with integral hood guard and anti-squirt feature. The manufacturer shall certify the unit to meet the requirements of ANSI/NSF 61, Section 9 and the Safe Drinking Water Act.

Note: Continued product improvement makes specifications subject to change without notice.



Standard finish is Stainless Steel

Optional Finishes (extra cost)

- Aztec Gold
- Galaxy Gray Marblyte™ (Bowl Only)
- Black Onyx Marblyte™ (Bowl Only)

Optional Accessories (extra cost)

- Vandal-Resistant Kit
- Easy-Flex™ Bubbler

Each OVL-II™ SBP consists of 1 carton as follows:

Fountain, Panel and Misc. Parts

Trap and service stop not furnished.

Shipping weight: 27 lbs.



OVL-II™ Face-Mounted Fountain With Back Panel

(CONTINUED)

MOUNTING INSTRUCTIONS

Refer to diagrams for rough-in of plumbing. Mount wall plate assembly to wall per the installation instructions. Hang fountain panel over the wall plate assembly. Attach fountain to wall plate assembly. Water service line and waste line are to be assembled as required. Final check for leaks and correct functions of fountain should be made. (For details see the installation instructions.)

CAUTION — Fountain must be securely bolted to wall.

OPERATING PRESSURES

Supply water-105 psi maximum

NOTE: For wall support required locations see installation instructions provided with panel and fountain.

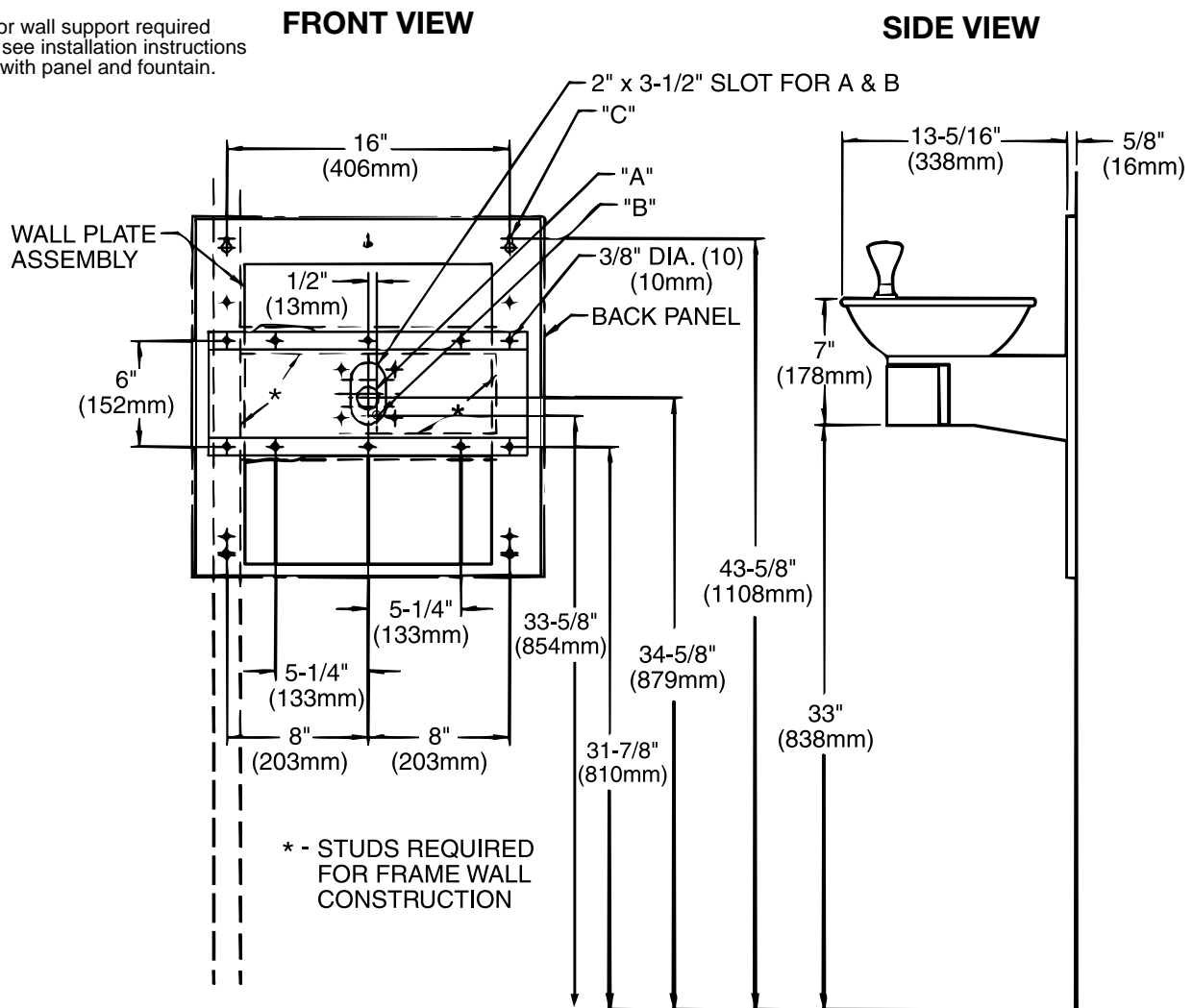
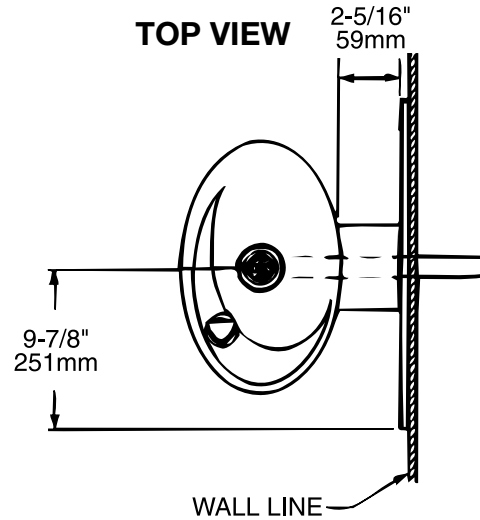

LEGEND:

- A = 1-1/4" O.D. WASTE TUBE (TRAP AND ELBOW NOT PROVIDED)
- B = 3/8" O.D. UNPLATED COPPER TUBE CONNECT (WATER INLET)
- C = 1/4" (6mm) DIA. HOLES FOR MOUNTING PLATE TO WALL

NOTE: A service supply stop should be installed at the fountain inlet line.

Halsey Taylor®